



Toll Free: 87 PERMATEX
(877-376-2839)

10 Columbus Blvd., Hartford,
Connecticut 06106

6875 Parkland Boulevard, Solon
Ohio 44139

Technical Data Sheet

Permatex® Eliminator® III Engine Degreaser

AAM Revised 05/11

PRODUCT DESCRIPTION

Permatex® Eliminator® III is a highly concentrated water based, foaming action engine degreaser specially formulated to quickly cut and remove grease, oil and dirt on all types of equipment. The product also inhibits rust and corrosion. Eliminator III is a new foaming action engine degreaser that is VOC compliant in all 50 states.

PRODUCT BENEFITS

- Quickly dissolves grease, oil and dirt
- Cleans iron, steel, aluminum, magnesium and copper
- Not harmful to metal, rubber, plastic or concrete
- Rinses off easily with water
- VOC compliant in all 50 states
- New foaming action
- Water based formula

TYPICAL APPLICATIONS

- Cleaning and degreasing automobile engines
- Industrial equipment
- Farm equipment
- Lawn mowers
- Garage Floors
- Tools

DIRECTIONS FOR USE

1. Provide adequate ventilation.
2. Warm up engine for easier cleaning and turn off. Remove air filter. Protect carburetor, distributor and any electronic components.
3. Shake can thoroughly before use. Note: There is no ball agitator inside the can. For best results, the aerosol can should be at room temperature before spraying.
4. Holding can 8 to 10 inches from the surface, press the nozzle and apply an even coat of product on the surface. Allow to foam for 10 to 20 minutes depending upon the amount of soil buildup. Repeat cleaning process if necessary.

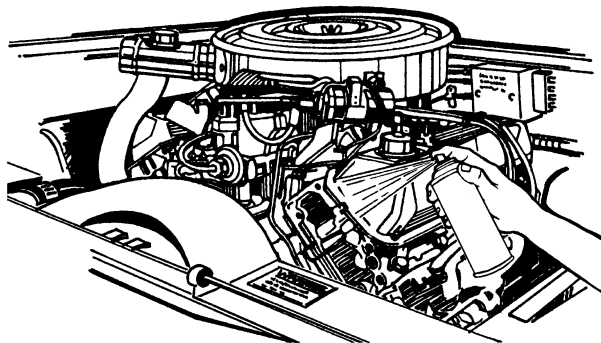

5. Rinse with a mild stream of water. Collect run-off with plastic sheet placed under the motor. Idle engine to dry.

For Cleanup

1. Dispose plastic sheet in accordance with state and local regulations
2. Clean hands with Permatex® brand hand cleaners.

PROPERTIES OF MATERIAL

	Typical Value
Chemical Type	Water based formula
Appearance	White foaming liquid
Odor	Mild citrus
Specific Gravity	0.99
pH	10.4
Flash Point	Aerosol, contents under pressure, consult MSDS
NFPA 704 Flammability Rating	1

GENERAL INFORMATION

This product is not recommended for use in pure oxygen and/or oxygen rich systems and should not be selected for use with chlorine or other strong oxidizing materials.

For safe handling information on this product, consult the Material Safety Data Sheet, (MSDS).

ORDERING INFORMATION

Part Number	Container Size
80043 (48TA)	20 oz. aerosol can

STORAGE

Products shall be ideally stored in a cool, dry location in unopened containers at a temperature between 8° and 28°C (46° and 82°F) unless otherwise labeled. Optimal storage is at the lower half of this temperature range.

NOTE

The data contained herein are furnished for information only and are believed to be reliable. We cannot assume responsibility for the results obtained by others over whose methods we have no control. **Permatex, Inc. specifically disclaims all warranties expressed or implied, including warranties of merchantability or fitness for a particular purpose, arising from sale or use of Permatex, Inc. products and disclaims any liability for consequential or incidental damages of any kind, including lost profits.** This product may be covered by one or more United States or foreign patents or patent applications.

NOT FOR PRODUCT SPECIFICATIONS.
THE TECHNICAL DATA CONTAINED HEREIN ARE INTENDED AS REFERENCE ONLY.
PLEASE CONTACT PERMATEX, INC., TECHNICAL SERVICE DEPARTMENT FOR ASSISTANCE AND RECOMMENDATIONS FOR YOUR SPECIFIC APPLICATION.
PERMATEX, INC., HARTFORD SQUARE NORTH, 10 COLUMBUS BOULEVARD, HARTFORD, CT 06106 PHONE - (1-87PERMATEX)